

# MINI ADAPTER PLATE - MINI-SH-4

APPROX WEIGHT: 37.47 lbs.  
DOES NOT INCLUDE WEIGHT OF POWER OR PACKAGING!!!

\*\*\* ANY ADDITIONS, DELETIONS, OR OMISSIONS MUST BE CORRECTED ON THIS DRAWING AS THIS DRAWING WILL BE CONSIDERED ALL INCLUSIVE \*\*\*

ALL GRAPHICS PROVIDED ARE FOR REFERENCE ONLY. IF CERTAIN DIMENSIONS ARE CRITICAL PLEASE VERIFY THOSE DIMENSIONS WITH YOUR SALESPERSON

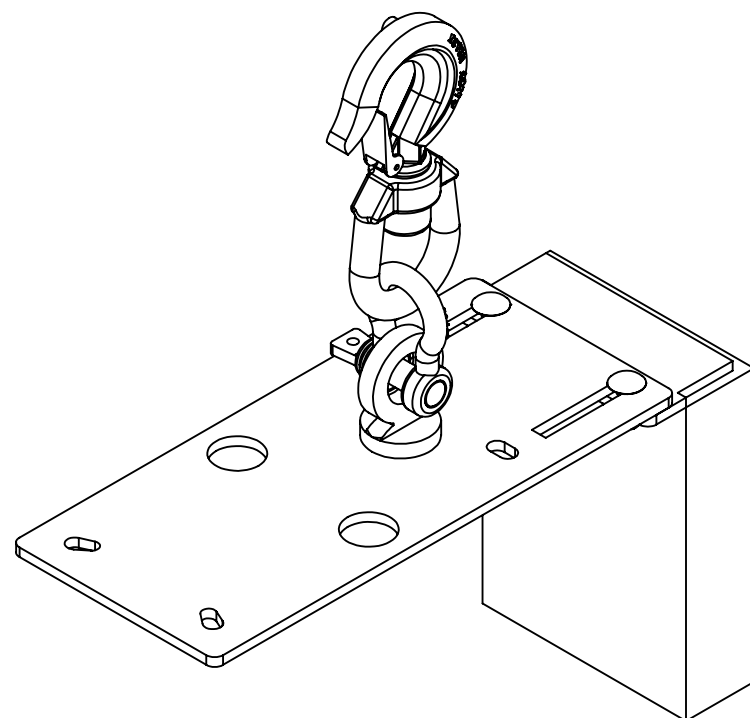
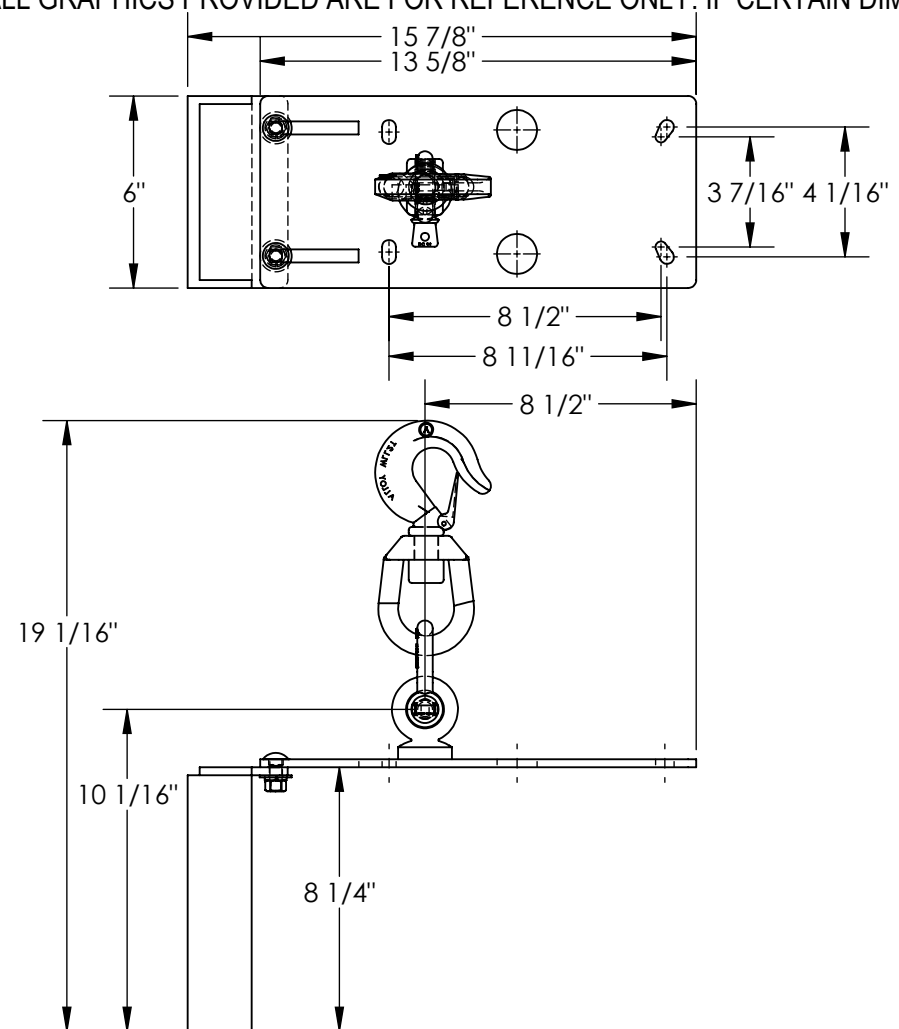

DIMENSION TOLERANCE ± 1/4"

## STANDARD FEATURES

- MODEL NUMBER IS MINI-SH-4
- OVERALL WIDTH IS 6"
- MAX OVERALL LENGTH IS 15 7/8"
- MIN OVERALL LENGTH IS 13 5/8"
- OVERALL HEIGHT IS 19 1/16"
- MAX CAPACITY IS 880 LBS.
- MINI ADAPTOR PLATE FOR USE WITH MINI-4
- MOVE COUNTER WEIGHT TO LEVEL THE HOIST
- INCLUDES SHACKLE & HOOK
- TOUGH BAKED IN POWDER COATED BLACK FINISH

## SPECIAL FEATURES

NONE

DIMENSION TOLERANCE ± 1/4"

I, THE UNDERSIGNED, AGREE THAT THE PRODUCT AS REPRESENTED SATISFIES DESIGN AND DIMENSION REQUIREMENTS. I ALSO ACKNOWLEDGE MY DUTY TO CONFIRM PRODUCT AND INSTALLATION COMPLIANCE WITH ALL APPLICABLE FEDERAL, STATE AND LOCAL REGULATIONS AND STANDARDS.

**ANY MODIFIED UNITS ARE NON-RETURNABLE**

[ ] As drawn      [ ] As marked

Signed: \_\_\_\_\_ Date: \_\_\_\_\_

Printed Name: \_\_\_\_\_

*LEAD TIME WILL START UPON RECEIPT OF SIGNED APPROVAL DRAWING*

DISTRIBUTOR'S NAME:		P.O.#
VESTIL MANUFACTURING		X
DRAWN BY: JWW		DATE: 8/5/2019
REFERENCE: X		SCALE: 1:6
QUOTED LEAD TIME: X		QUOTE # X
		SALES: X
		FILE NAME: 49-007-014-001

FOR INTERNAL USE ONLY PROJECT SIGN OFF	
SALES	
ENG.	
FAB.	
POWER	